

FLOW VALVES

MODEL-707



ISO 9001:2008 REGISTERED



HVAC Systems

Specifications

The **707 Flow valve** is a wafer type butterfly valve with an integrally bonded elastomer liner. Requiring absolutely no form of maintenance the **707** is a perfect "Fit and forget" valve. Available with either a flangeless or lugged body, in a size range of 50-600 mm, a pressure rating of up to PN 24 and offered with latching lever or actuation as well as different combinations of disc and seat materials, the **707** is a truly versatile valve.

Features

Benefits

Vulcanized Integrally bonded body seat	Easy and trouble free mounting in the pipeline. No maintenance. No tearing and distortion of liner. Exceptionally long seat life. Uniform sealing. Suitable for vacuum and high flow applications.
Extended neck	Allow for 2" and up insulation
Primary and secondary seals integral with body lining	Ensures compatibility with media.
Different disc and seat combinations available	Suitable for a wide range of applications.
Weatherseal feature (see below)	Atmospheric sealing to valve internals.
Spherical machined and polished disc	Ensures longer seat life, easier operation and tight shut-off.
One-piece shaft	High torsional capabilities with zero disc deflection
Epoxy coted body and gear	Excellent corrosive resistant

Applications

General Applications	Continuous Working Temperature Range	Maximum Working Pressure	Disc Material	Seat Material
Water, hot gases, powders, air slurries and aqueous slurries of an abrasive nature, HVAC SYS	Liquids -10°C to 120°C Dry services -10°C to 100°C	16 bar	D.I Nylon coated	EPDM
Oils, fuels, water, air, gases, powders, pellets, slurries etc.		16 bar	Stainless steel	NITRIL EPDM PTFE
Brines, sea water, estuary water, marine bilge and ballast systems	Liquids -10°C to 80°C	16 bar	Aluminium Bronze	

Weatherseal Feature

The acetal bush (see 1 opposite) at the top end of the shaft acts as a bearing, thereby reducing actuator torque.

The Weatherseal (2) provides atmospheric sealing to the valve interior.

The Weatherseal design is available on 50mm to 300mm sizes.

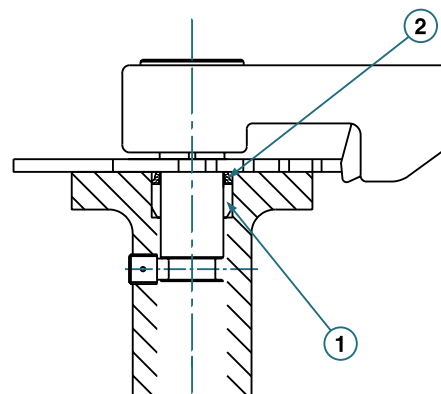

707 Dimensions

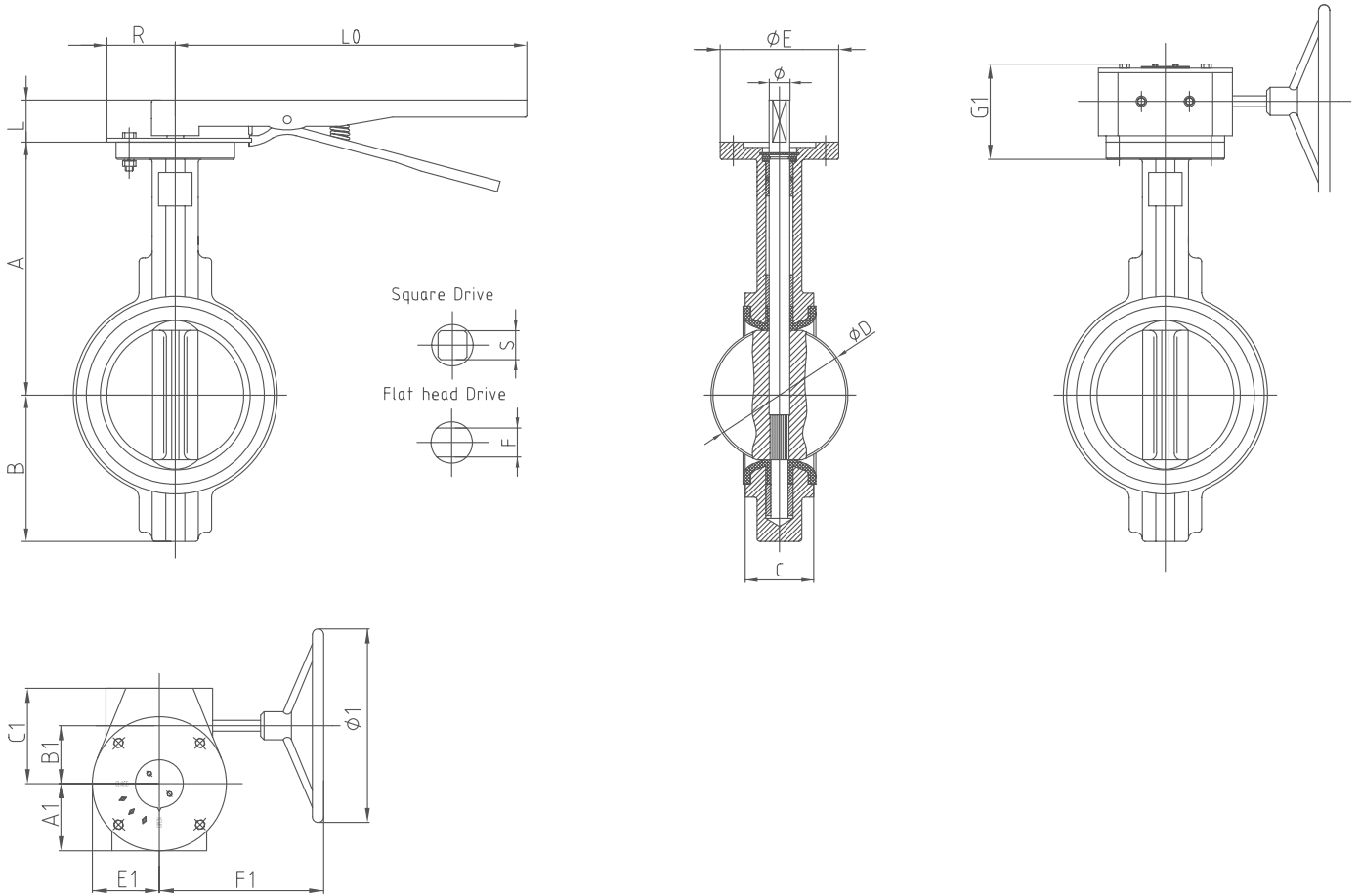

	A	B	C	D	L	E	Top Flange	Ø	F	S	LO	R	A1	B1	C1	E1	F1	G1	Ø 1
DN40	133	69	33	42.6	32	90	F07	12.6	10	9	266.7	52	52	45	74	52	152.5	75	150
DN50	161	80	42.04	52.6	32	90	F07	12.6	10	9	266.7	52	52	45	74	52	152.5	75	150
DN65	175	89	44.68	64.3	32	90	F07	12.6	10	9	266.7	52	52	45	74	52	152.5	75	150
DN80	181	95	45.21	78.8	32	90	F07	12.6	10	9	266.7	52	52	45	74	52	152.5	75	150
DN100	200	114	52.07	104	32	90	F07	15.77	12	11	266.7	52	52	45	74	52	152.5	75	150
DN125	213	127	54.36	123.3	32	90	F07	18.92	14	14	266.7	52	52	45	74	52	152.5	75	150
DN150	226	139	55.75	155.7	32	90	F07	18.92	14	14	266.7	52	52	45	74	52	152.5	75	150
DN200	260	175	60.6	202.4	45	125	F10	22.1	17	17	359	75.2	75	62.75	101	75	250	86	300
DN250	292	203	68.3	250.7	45	125	F10	28.45	22	22	359	75.2	75	62.75	101	75	250	86	300
DN300	337	242	76.9	301.5	45	125	F10	31.8	24	22	505	75.2	81	80	118	81	227	83	300
DN350	368	267	76.5	333.5	45	125	F10	31.8	24	22	505	75.2	81	80	118	81	227	83	300

* All sizes are in mm, weight in kg, torque in N.M.

* For mor information, and bigger sizes please contact us.

* For PN-25 Valve D.I. Body and disk

* For PN-40 Valve A216 Gr WCB Body and disk

Material Specification

Part	Material of Construction
Body	Cast Iron to BS 1452 Gr 220
	SG Iron to BS 2789 Gr 420/12
	C/S to ASTM A216 Gr WCB
Body liner	EPDM (WRC Approved)
	NITRILI
Disc	SG Iron to BS 2789 Gr 420/12 with nylon coating
	Al. Bronze to BS 1400 Gr AB2/AB1
	S/S to ASTM A351 Gr CF8/CF8M edge polishd
Shaft	AISI 410 coated for permanent dry lubrication
Bearings	50 - 300mm - Acetal
	350 - 600mm - Phosphor Bronze
Standard flow control lever	SG Iron to BS 2789 Gr 420/12

Torque Data - Nm*

Valve Size (mm)	Line Pressure (bar)		
	6	10	16
50	5.5	6	7.5
65	7	9	11
80	9.5	11	12
100	16	17	18
125	46	52	55
150	68	69	72
200	105	120	163
250	210	242	303
300	220	350	425
350	452	452	514
400	813	813	925
450	1047	1047	1192
500	1325	1325	1506
600	2662	2662	3029

* Safety factor not included

Accessories

707 butterfly valves can be supplied with factory fitted pneumatic, hydraulic or electric actuators along with other accessories such as limit switches, manual overrides, positioners etc. to form a complete flow control package. Heavy duty gear units are supplied for valves to be fitted with electric actuators.

Installation, Operating and Maintenance instructions for the **707** are available on request.

Pressure Rating

Seat	Rating (bar)	Test Pressures (bar)	
		Body / Disc	Seat
Black Nitrile/EPDM	16	24	17.6

Standards

	Size (mm)	Standards
Face to Face	50 to 600	BS 5155 - Wafer Short API 609 - Category A MSS SP 67 -Narrow Body ISO 5752 - Short
Valve Design		BS 5155 - Specification for Butterfly Valves API 609 - LugandWafertype ButterflyValves MSS SP 67 - Butterfly Valves ISO - Metal valves for use in flanged pipe systems. Face to face and centre to face dimensions
Testing		ISO 5208, ISO 7005-1-2-3

Operation

Valve Type	Size Range (mm)
Flow Control Lever	50 to 300
Standard Gear Unit	50 to 600

Flanges

The valves are of short pattern type and have been designed to fit between flanges without gaskets drilled to BS 10 Tables 'D', 'E', and 'F', ANSI 125/150, DINPN 10/16, BS 4504 (PN10/16), Tables 6 to 9 of IS : 6418, Tables 10 to 20 of IS : 6392 and Tables 4 to 6 of IS : 1538

Valve Selection

1. Ensure to select a valve with design specifications which meet the fluid type and the pressure and temperature conditions required.
2. Lubricants are applied to discs, rubber seats and PTFE seats as standard to protect their surfaces. Oil-free treated types are available as option. Contact 707 Corporation or its local distributors for the details.
3. Contact 707 Corporation or its local distributors for service with pulverulent bodies.

Storage and Handling

Valves must be stored in dry, clean and corrosion-free environment with no direct exposure to the sun, leaving valves open by 10° for prevention of permanent distortion of resilient seats. Refrain from overloading valves and their actuators, such as storing them in piles or placing other objects on them.

Mounting on Pipelines

1. Valves must be mounted on flanges only after flanges have been welded to pipes and cooled down to the atmospheric temperature. Otherwise, welding heat may affect the quality of resilient seats.
2. Edges of welded flanges must be machined for smooth surface finish so that they may not damage resilient seats during valve mounting. Flange faces must be free from damage or deformation, and be cleaned to remove rust or any other foreign objects so that there will be no concern of external leakage through valve and flange connections. Gaskets are not required for mounting 707 butterfly valves.
3. Clean flanges and pipe bores to thoroughly remove welding spatters, scales and other foreign objects which may have been left inside.
4. Accurate centering of each couple of upstream and downstream pipes is essential for trouble-free operation of valves mounted between them. Incorrect centering shown in Fig. 1 must be by all means avoided.

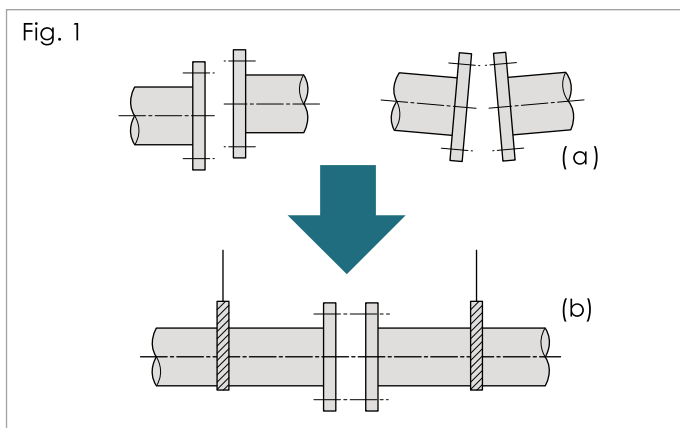

5. For valve mounting, set jack bolts under the pipes for flat support at the same height, and adjust the flange-to-flange distance so that some 6 mm to 10 mm room may be allowed beside the both sides of the valve body. Remember that valves here must be left open only by 10° from the fully closed position.
6. Set two bolts into the lower mounting guides of a valve and mount it carefully so that flange faces may not damage resilient seats. (Fig. 2)
7. Then set another two bolts into the upper mounting guides of a valve, ensuring the correct centering between pipes and the valve.
8. Trial open the valve to check to see if there is no disturbing contact between the valve disc and the flanges.
9. Remove the jack bolts, set all bolts around the valve body and tighten them alternately and diagonally till the flanges contact the valve body (Fig. 3 and 4). Refer to the table

shown right for **recommended torque values.**

DN	N·m (kgf·m)	DN	N·m (kgf·m)
50	63(6)	250	177(18)
65		300	
80		350	
100		400	265(27)
125	111(11)	450	392(39)
150		500	
200		600	539(54)

Fig. 2

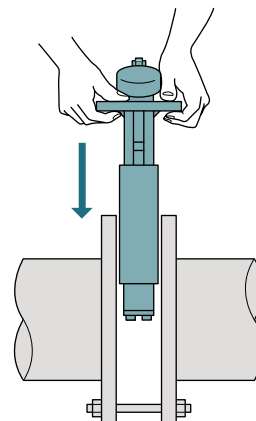

Fig. 3

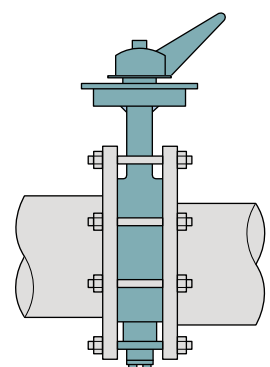
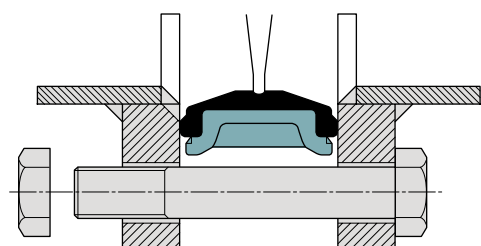

Fig. 4



10. For mounting actuated valves, provide valve supports to prevent bending of valve necks and reduce valve and pipe vibration.
11. Don't step on valve necks or valve handwheels.
12. Don't mount valves of DN350 and larger with their operations upside down.
13. Don't mount butterfly valves directly to check valves or pumps, which may cause damage to them by the disc contacts.
14. Don't mount valves to downstream sides of elbows, reducers or regulating valves where fluid velocity changes. It is recommended to install valves approximately 10 times of the valve nominal sizes away from them for such cases.
15. Mount valves taking consideration of the effects which discs are given by fluid velocity or pressure changes in the pipings. Refer to the illustrations. (Fig.5)
Contact 707 Corporation or its local distributors for the details.

Valve Operation

1. Valves equipped with manual operators such as levers, and handles of gears must be ONLY MANUALLY operated. Application of an excessive external force to operate valves may result in malfunction of valves and their operators.
2. Ensure to fully open valves before a loop test of the piping system is carried out with line pressure higher than the nominal pressure of tested valves. Never use closed valves in place of blind flanges.
3. When valves need to be dismantled from pipes for maintenance or any other cause, ensure to thoroughly release the line pressure beforehand. Loosening piping bolts under line pressure causes a danger. Any residual fluid left inside the pipeline must be completely drained.
4. Users should contact 707 Corporation or its local distributors for technical advice, when valves should be continuously pressurized while left open by 30 or less.
5. Don't use position indicators to operate valves, or overload position indicators. This may cause damage to indicators.
6. Ensure to use blind flanges when butterfly valves are mounted at the end of pipelines.
7. Standard actuators are referenced in this catalog for actuated valve operation. Contact 707 Corporation or its local distributors for mounting optional actuators.
8. Contact 707 Corporation for service at hopper or pump outlets.
9. Avoid touching gear operators and actuator stopper bolts accidentally.
10. It is recommended to perform periodical inspection for
 - Making sure of valve opening degree
 - Checking loosened bolts and leakage at each connection
 - Checking vibration and noise
11. Refer to instruction manual for other precautions. Also refer to actuator catalogs and instruction manuals for actuated valves.

Fig.5

- Mounting to bent pipe
- Mounting to pump outlet

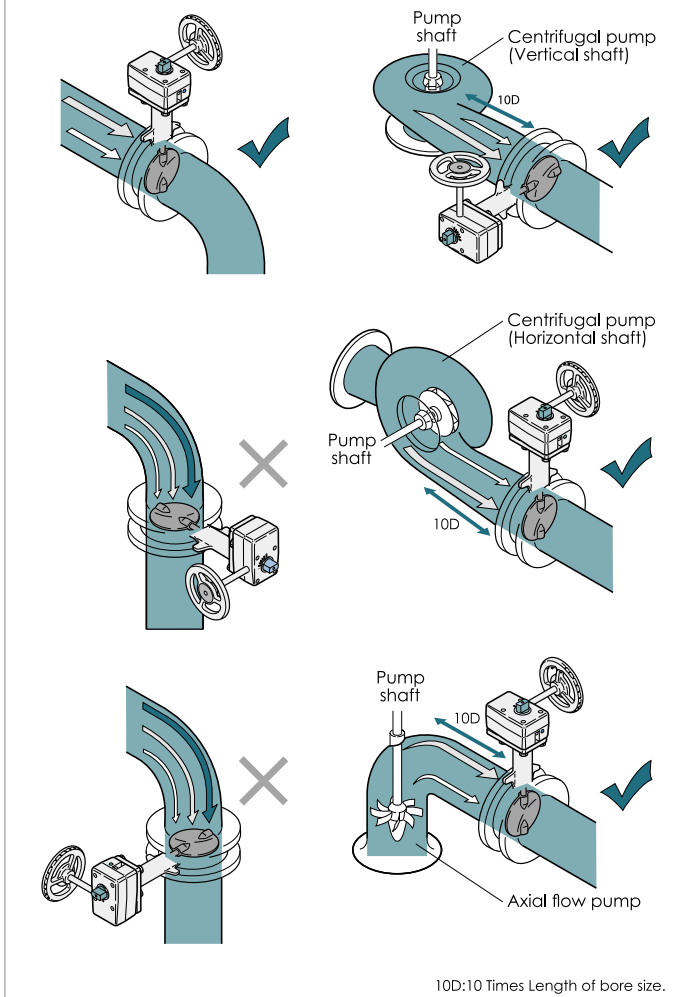

FLOW VALVES

30-143 SHIHUNG INDUSTRIAL TOOL CENTER
SEOUL - KOREA

FLOW VALVES

23 DIANDA ST. TIJANJIN - CHINA

FLOW VALVES

5003 COTE DE LIESSE QC H8T 3G4,
MONTRIAL - CANADA